

USER MANUAL

PORTABLE ELECTRIC AIR PUMP

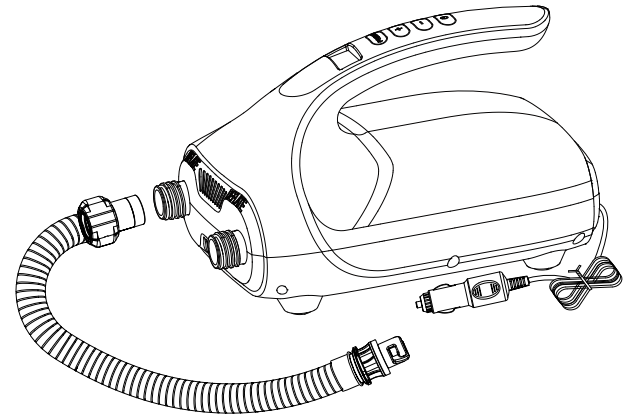

MANUFACTURED BY:
Jobe Sports International
Heerewaardensestraat 30,
6624 KK Heerewaarden
The Netherlands

tel. +31 (0) 487 573090
e-mail: info@jobesports.com
url: www.jobesports.com



CATALOGUE

I. Product Introduction.....	1
II. List of Accessories.....	1
III. Details of Accessories.....	1
IV. Safety Instructions.....	2
V. Inflation Operation.....	3-4
VI. Deflation Operation.....	4
VII. Precautions.....	4-5
VIII. Fault Handling.....	5
IX. Maintenance and Storage.....	5
X. Suggestions.....	5

I. Product Introduction

Thank you for purchasing this product, HT-782 is an intelligent DC electric pump with the preset pressure LCD screen, which can be used for inflatable tent, SUP, etc. Thanks to the intelligent pressure system, for example, if a pressure value is preset, when the pressure reaches the preset pressure value, the pump will automatically stop inflating.

This product also can deflation, and when the inflatable product is not used, you can use the air pump to empty the air inside for folding and storage.

II. List of Accessories

Please make sure that the following accessories are in the box before using it, if any missing, please contact with the local service agents

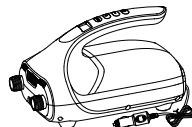
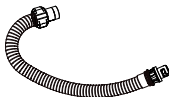
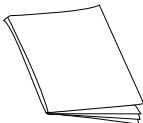
Air pump	Hose	Instruction Book
		

III. Details of Accessories

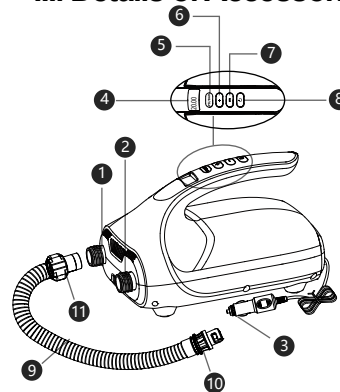

①	Inflation inlet
②	Deflation outlet
③	DC plug
④	Pressure value LCD screen
⑤	Pressure unit toggle button
⑥	Pressurizing button
⑦	Decompressing button
⑧	On/off button
⑨	Hose
⑩	Air tap
⑪	Flexible conduit adaptor

IV. Safety Instructions

⚠ WARNING In order to reduce the risk of injury, please keep children away from it. Always supervise children and incapacitated person contacting or using this air pump.

⚠ WARNING Children shall be kept far away from this product and wire.

⚠ WARNING This product is not applicable for the person with declining physical strength, sensory ability or mental capacity, the person lack of skill and the mentally retarded person, unless they are under the protection of their guardians, supervised and directed at the same time.

⚠ WARNING Before moving, maintaining, repairing or adjusting this product, please first pull out the DC plug from the socket.

⚠ WARNING Please do not bury the wire in the soil, and it shall be place in the safe zone where it won't be damaged by mower or other equipment.

⚠ WARNING If the power wire is damaged, the power wire must be changed by the manufacturer or its service agent or the similar authorized personnel, in case of any risk.

⚠ WARNING If you are standing in a place with water or your hands are wet, please don't plug or pull the DC plug.

⚠ WARNING Before inflating, please pay attention to check the maximum bearable pressure of the inflatable product, because the air bag may be damaged upon exceeding the maximum bearable pressure.

⚠ WARNING Before using, please check the cigarette lighter socket to make sure that there is no rust or residue inside. The cigarette lighter socket with poor electric conduction may cause overheating of the product or power source, which will damage the product.

⚠ WARNING The purpose of using this product is limited to the description in the instruction book.

V. Inflation Operation

- * Connect the end with flexible conduit adaptor (11) of the hose with the air pump inflation inlet (1), and twist clockwise to tighten it, as Figure 1
- * Install the other end of the hose into the supporting air tap of the air bag (step① in Figure 2), and twist clockwise to tighten it, and then insert the inflation valve of the air bag and twist clockwise to fix it (step ② in Figure 2).
- * Plug the DC plug into the 12V DC socket.
- * Press the pressure unit toggle button (PSI/BAR) to select the unit you need.
- * Press the pressurizing button (+) or decompressing button (-) to set the pressure value you need, with the range of the pressure value from 0 to 20PSI, (1PSI=0.0689BAR)
- * After finishing the above steps, press the power switch button (⏻) to start to inflate.
- * During the inflating process, you can press the pressurizing button (+) or decompressing button (-) to increase or reduce the pressure value, press the pressure unit toggle button (PSI/BAR) to switch the unit, and press the On/Off button (⏻) to stop.
- * Press and hold the On/Off button for 3 seconds to directly start the high pressure pump.

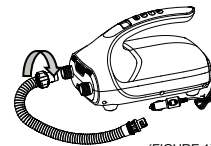

(FIGURE 1)

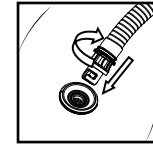

(FIGURE 2)

- * When the pressure reaches the set value, the air pump will stop working automatically.
- * After completing the inflation, pull out the DC plug from the 12V DC socket.
- * After pulling out the DC plug, please take down the hose from the air pump and air bag and store it.

PORTABLE ELECTRIC AIR PUMP

- * Notice: The factory set pressure value of the air pump is 10PSI (10PSI=0.689BAR), and at the time of the secondary use, the set pressure value for the last time use will be displayed by default.
- * Notice: After powered on, if there is no operation within 2 minutes, the air pump will enter standby mode, and the machine can be initiated by pressing the power switch button (⊖).

VI. Deflation operation

Remove the hose from the inflation inlet, Connect the end with

- * flexible conduit adaptor (11) of the hose with the air pump deflation outlet (2), and twist clockwise to tighten it, as Figure 3, and the other end shall still be to the airbag.

Press the button of the power switch (⊖) of air pump, and start the

- * deflation until all the gas is discharged, then the power can be turned off to stop the deflation.

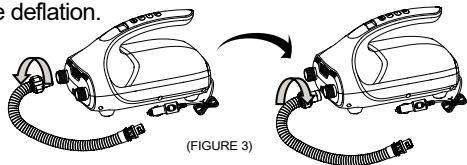

(FIGURE 3)

VII. Precautions

- * The applied power source must be the 12V DC power source (as Figure 4).
- * Do not block the inflation inlet (1) and Deflation outlet (2), and ensure that the inflation inlet (1) and Deflation outlet (2) shall remain smooth at all times.
- * Observe the local waste treatment provisions, and it is not allowed to throw the air pump away randomly.
- * Don't use this product when the hose is damaged, and please change the hose immediately.
- * Don't pull out the hose when inflating, because that the high pressure may hurt the physical body.
- * Don't make the air pump work for more than 20 minutes, because that motor overheating may cause internal damage; and the air pump shall be fully cooled for 30 minutes after continuously working up to 20 minutes.

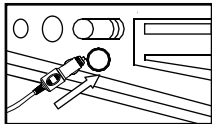

(FIGURE 4)

PORTABLE ELECTRIC AIR PUMP

- * Please don't use this air pump if any part is damaged, and please contact with the professional personnel to repair it.
- * This product shall not be exposed to the rain or immersed in water.
- * In order to prevent risk, the inflation inlet shall not be forward to face or body. Please don't not leave while inflating.
- * Please start the car when using the product, in case of unnecessary damage.

VIII. Fault Handling

Fault	Inspection	Solution
The air pump cannot be started normally.	<ol style="list-style-type: none"> 1. The power source is not plugged properly. 2. The fuse in DC plug (7) is burnt out. 3. Overheating or overload causes motor stop. 	<ol style="list-style-type: none"> 1. Make sure that the power wire is plugged in the 12V DC socket. 2. Change the fuse. 3. Cool the motor and restart it. 4. If the problem cannot be solved, please contact local service agents or similar authorized personnel to change the product.
The machine displays HOT	Check if the air pump is working too long and its inside is overheated.	30-minute cooling
Slow or abnormal inflation or deflation.	<ol style="list-style-type: none"> 1. Check whether the hose is blocked or cracked. 2. The joint between the hose and air pump or air bag is not installed properly. 	<ol style="list-style-type: none"> 1. Change the hose or make it unblocked, and check whether the hose is cracked. 2. Reinstall the hose. 3. If the problem cannot be solved, please contact local service agents or similar authorized personnel to change the product.

IX. Maintenance and Storage

- * After using, or if you want to move, maintain or adjust the product, please first pull out the DC plug from the socket.
- * when it is idle, it shall be properly stored after being fully cooled.
- * It shall not be exposed to the rain or immersed in water.
- * Please store it in the dry and ventilated place.

X. Suggestions

The warranty period of this product is one year, and it is suggested to use the original accessories. For any fault not caused by using the original accessories, it shall be out of the warranty scope.

USER MANUAL

EXTERNAL POWER SUPPLY

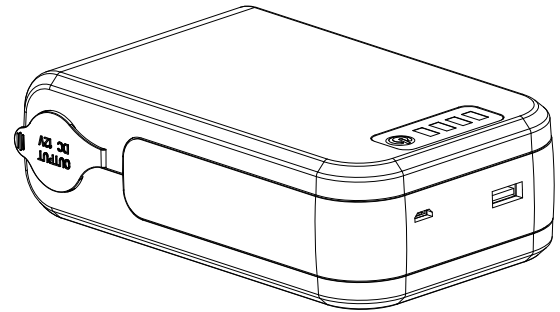

MANUFACTURED BY:
Jobe Sports International
Heerewaardensestraat 30,
6624 KK Heerewaarden
The Netherlands

tel. +31 (0) 487 573090
e-mail: info@jobesports.com
url: www.jobesports.com



CATALOGUE

I. Product Diagram	1
II. Safety Instructions	1-3
III. Purpose	3
IV. Battery Power Level Display.....	4
V. Charging Diagram	4
VI. Basic Parameters.....	4
VII. Precautions	5
VIII. Maintenance and Storage	5
IX. Suggestions	5

VII. Precautions

- * Do not attempt to dry this product with a hairdryer, microwave oven or other heat sources.
- * Do not allow this product to work for more than 30 consecutive minutes, because motor overheating might cause internal damage. Please allow the product to cool for 30 minutes after 30-minute continuous operation.
- * Do not use this product while it's being charged.
- * It's prohibited to make the product get wet in the rain, become damp or soak in the water because it's not waterproof.
- * Observe the local waste disposal regulations. Never discard the product randomly.
- * The USB cable is only used for charging. It is recommended that this product should not be used during charging.

VIII. Maintenance and Storage

- * After using, or if you want to move, maintain or adjust the product, please first pull out the DC plug from the socket.
- * when it is idle, it shall be properly stored after being fully cooled.
- * It shall not be exposed to the rain or immersed in water.
- * Please store it in the dry and ventilated place.

IX. Suggestions

The warranty period of this product is one year, and it is suggested to use the original accessories. For any fault not caused by using the original accessories, it shall be out of the warranty scope.

IV. Battery Power level Display

The display shows the battery power level at the time of battery charging and discharging (as shown in the following diagram).

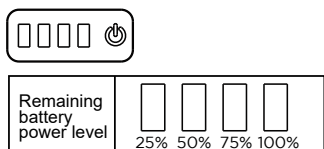

Notes:When the battery power level is “25%”, please charge the battery. This product is available with battery overcharge and over-discharge circuit protection, which can effectively protect the service life of the battery.

V. Charging Diagram

Please use compatible USB charging cable to charge the product. It is recommended that this product should not be used during charging (figure 3).

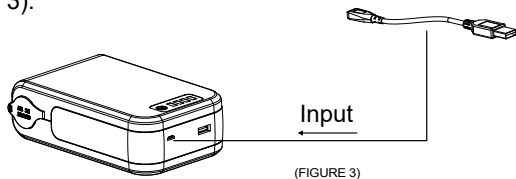

VI. Basic parameters

Charging input: DC5V/1000mA

Dimensions: 15.5cm×9.52cm×4.8cm

Charging time: About 9 hours

Cigarette lighter output: DC12 15A

Power: 140W

Lithium battery capacity: 4000mAh

I. Product Diagram

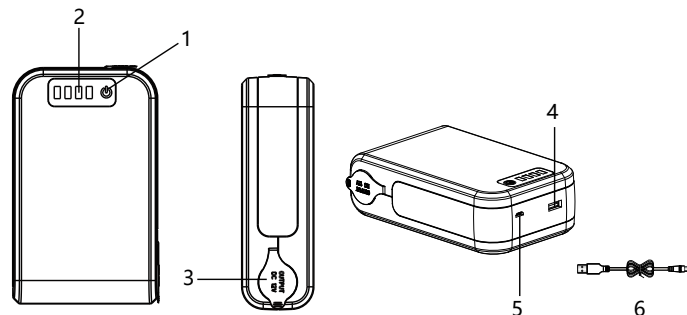

1. On/Off battery indicator
2. Battery indicator
3. Cigarette lighter socket

4. USB outlet
5. USB Charging inlet
6. USB charging line

II. Safety Instructions

⚠ WARNING In order to reduce the risk of injury, do not allow children to use it. Keep children and those who are incapacitated off it.

⚠ WARNING Children shall be kept far away from this product and wire.

⚠ WARNING This product is not applicable for the person with declining physical strength, sensory ability or mental capacity, the person lack of skill and the mentally retarded person, unless they are under the protection of their guardians, supervised and directed at the same time.

⚠ WARNING Please do not bury the wire in the soil, and it shall be place in the safe zone where it won't be damaged by mower or other equipment.

⚠ WARNING If the power wire is damaged, the power wire must be

EXTERNAL POWER SUPPLY

changed by the manufacturer or its service agent or the similar authorized personnel, in case of any risk.

⚠ WARNING If you are standing in a place with water or your hands are wet, please don't plug or pull the DC plug.

⚠ WARNING Before using, please check the cigarette lighter socket to make sure that there is no rust or residue inside. The cigarette lighter socket with poor electric conduction may cause overheating of the

⚠ WARNING It is strictly forbidden to place the product in a high-humidity environment, otherwise the internal circuit of the product might be short-circuited, causing serious damage to the product.

⚠ WARNING Do not throw this product into fire for fear of explosion, battery leakage or other dangers.

⚠ WARNING Do not disassemble or break the product randomly for fear of damaging the product.

⚠ WARNING Avoid keeping or using this product under strong sunlight. Prolonged sun exposure will damage the performance of the product, resulting in overheat and line problems.

⚠ WARNING Do not use or store this product in an environment where the temperature is too low or too high, which might trigger automatic protection of the product and cut off the charging of the digital product.

⚠ WARNING Please use this product in a relatively safe environment, and keep it away from flammable/explosive liquids, gases or explosives.

⚠ WARNING Before charging this product, please verify that the specifications of the adapter match the product. Incompatible adapters might cause damage to the product or cause risky overload.

When the product is not in use, please put it in a dry and ventilated place, and prevent it from colliding with metal objects for fear of short circuit. Please pay attention to heat dissipation and ventilation during use, so as to avoid danger due to excessive temperature.

⚠ WARNING If product swelling or leakage is found, please stop using this product.

EXTERNAL POWER SUPPLY

⚠ WARNING Do not disassemble the device without authorization. This product does not contain spare parts that can be disassembled/maintained by the user.

⚠ WARNING Do not cover or obstruct the product with paper or other objects for fear of affecting heat dissipation and cooling of the product.

⚠ WARNING In order to avoid injury or property damage, unplug the power cord when not using the product.

⚠ WARNING If leakage occurs and the liquid splashes into the eyes accidentally, do not rub your eyes but rinse your eyes with clean water immediately instead. If the symptom is serious, please go to hospital.

⚠ WARNING Product or power source, which will damage the product. Power the product with a cigarette lighter plug less than 15A

⚠ WARNING The purpose of using this product is limited to the description in the instruction book.

III. Purpose

1. This product supplies power to air pumps, mobile phones, tablet computers and other devices (Figure 2).
2. Power the product with a cigarette lighter plug less than 15A (Figure 1/2).

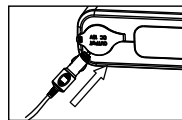

(FIGURE 1)

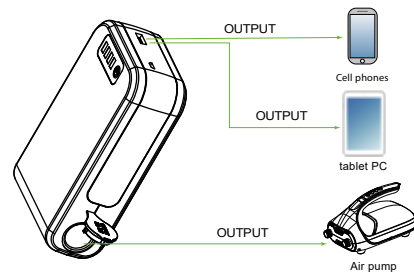

(FIGURE 2)