

# Quick Installation Guide

This brief guide will take you through the installation of your new RLX C G2 floodlight. For additional in-depth product information, operation and maintenance issues, please contact your local Glamox distributor or go online [www.glamox.com](http://www.glamox.com) for further information.

## Box content

- Fully assembled RLX C floodlight (VAC or 24 VDC version)
- Quick installation guide
- Recyclable cardboard

## Required tools

- Umbraco 4mm
- Electrician's screwdriver (slot)
- 2x 17mm combination spanners
- 24mm combination spanner
- Wire stripper
- Additional cable glands (optional)



### OPTICAL RADIATION

Do not stare at operating lamp.  
May be harmful to the eyes.

The RLX C G2 should be opened or dismantled by Glamox only<sup>1</sup>. The customer can, however, perform all power connections described in the Quick Installation Guide or in the RLX User Manual without the latter requirement being exceeded. If the terminal box has been moulded, do not open it!

## 1 Mounting and pointing

To attain the long lifetime, please make sure that the heat sink on the back of the chassis has an adequate passage to allow air to flow freely – this for the highest possible cooling performance. For outdoor applications it is important that the external cables and cable glands point downward. If the RLX C G2 is desired recessed, please make sure to have at least 200 mm of free space around the unit for cooling purposes. Shall only be installed by a qualified electrician.

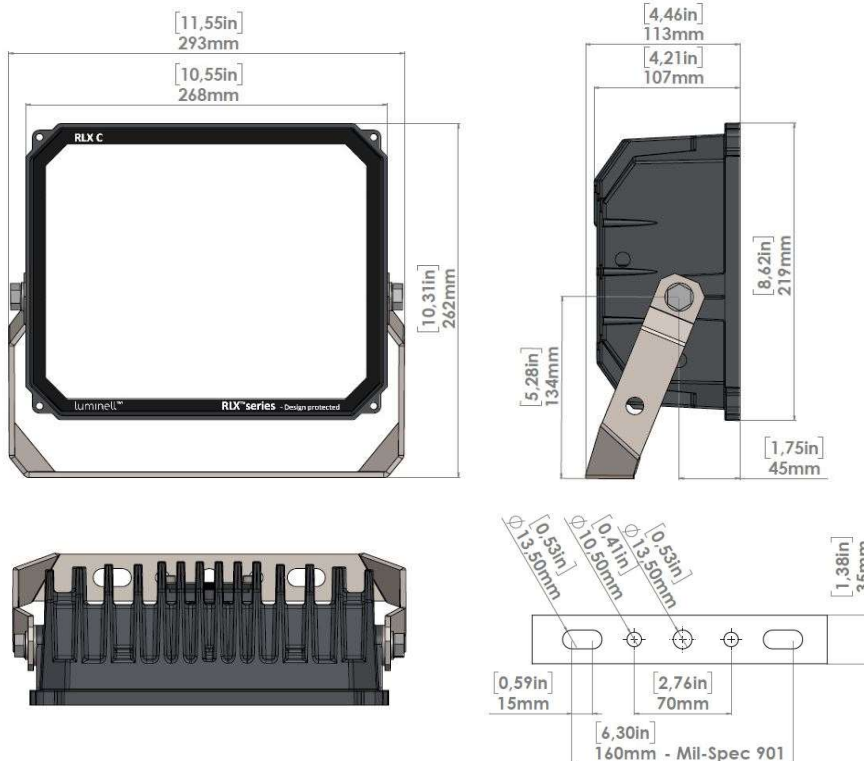

### CAUTION!

Crush hazard! Be aware of moving parts when lifting and mounting the floodlight. Shall only be installed by a qualified electrician.

<sup>1</sup> Or personnel authorized by Glamox.

## 2 Power connections



### DANGER!

Electric shock risk, 100 – 277 VAC. Ensure that power is disconnected before carrying out any connections!



- Shall only be installed by a qualified electrician.
- Do not connect the RLX C G2 floodlight on the same power circuit as floodlights using ballast units (such as high-pressure sodium, metal halide or other high intensity discharge lamps).
- Make sure to replace unused cable glands with blind caps M20x1.5. Warranty will be voided if replaced cable glands / blind caps are not UV and weather resistant, -40°C to 80°C. In addition, it is the installer's responsibility to ensure that cable and cable glands are appropriate for each other.



Unscrew the back plate using an Umbraco 4mm. The leak proofing seal have a grease (OKS1110) applied to it – if this is wiped off, please make sure to replace it in order to make the housing leak proof. Each floodlight is delivered with one cable gland. Make sure to tighten all four M5 bolts with 5Nm.

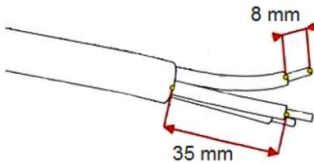

The RLX C G2 has two threaded M20x1.5 holes, each with a blind cap or a cable gland. Use a power cable with appropriate dimensions so that the cable gland connection is sealed. Make sure to tighten cable gland and cap nut with \*5.5Nm.

*\*The specified torques where determined under laboratory conditions according to EN 62444. The torques are therefore guide values, and torque should be observed under normal climatic conditions for stop ends.*

Conductor: Multi core, AWG 16–14 / 1.5-2,5 mm<sup>2</sup>

To connect the cables to the spring-loaded conductor connection, simply press down a small screwdriver (preferably a slot screwdriver) as shown in the figure and place the conductor in the spring cage. Repeat this for each conductor. For the RLX C G2, follow the circuit outlined below when carrying out the connections.

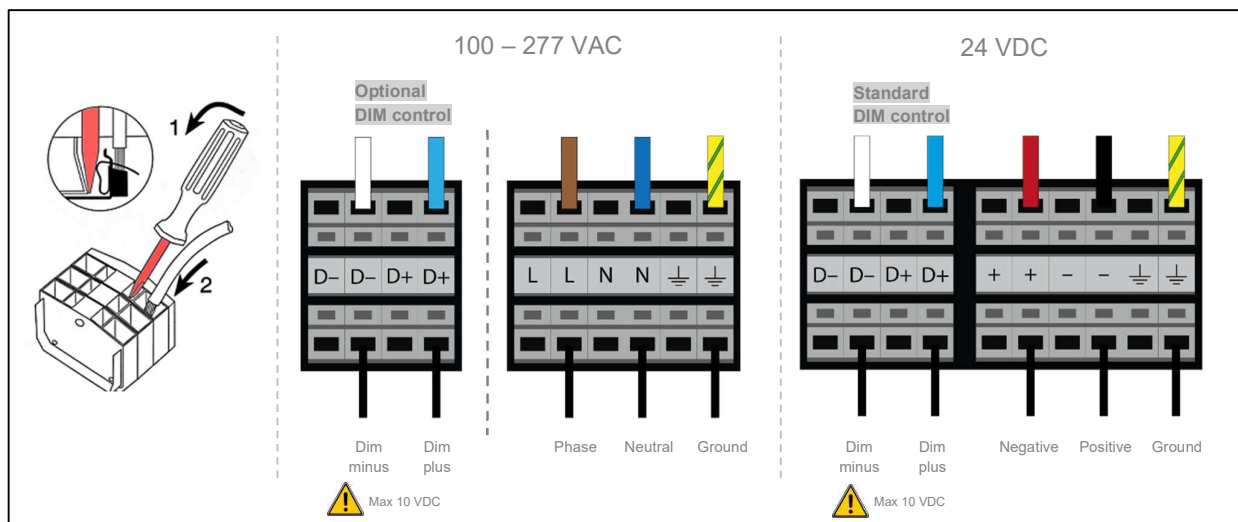

### Note on coated print circuit board:

In order to withstand extreme conditions even without the glass on, the print circuit boards in the RLX series are coated with a premium quality tough-gel. During the hardening process, this gel may generate some dew, which could be visible on the inside of the glass on brand new products. This is not a product failure, and the dew will disappear over time.